

**RIGHT ANGLE PLUG CRIMP TYPE**

**CABLE 2.6/50 D**

**R199.005.260**

Series : MC-CARD

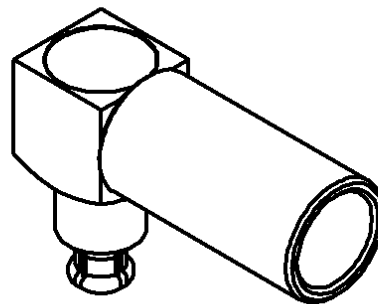
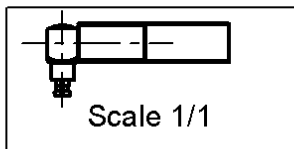
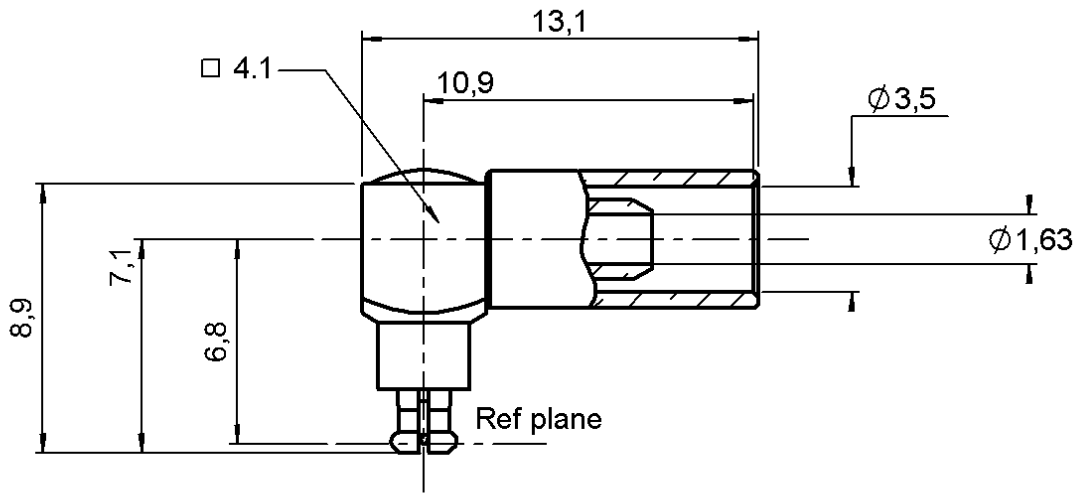

All dimensions are in mm.



COMPONENTS	MATERIALS	PLATINGS (µm)
BODY	BRASS	NICKEL 2
CENTER CONTACT	BRASS	GOLD 0.5 OVER NICKEL 2
OUTER CONTACT	BERYLLIUM COPPER	GOLD 1.3 OVER NICKEL 2
INSULATOR	PTFE	
GASKET	-	
OTHERS PARTS	BRASS	NICKEL 2
-	-	-
-	-	-

Issue : 0227 B

In the effort to improve our products, we reserve the right to make changes judged to be necessary.



**RIGHT ANGLE PLUG CRIMP TYPE**

**R199.005.260**

**CABLE 2.6/50 D**

Series : **MC-CARD**

**PACKAGING**

Standard	Unit	Other
<b>1</b>	-	<b>Contact us</b>

**SPECIFICATION**

**ELECTRICAL CHARACTERISTICS**

Impedance		<b>50</b> Ω
Frequency		<b>0-8</b> GHz
VSWR	<b>1.15</b> +	<b>0.015</b> x F(GHz) Maxi
Insertion loss		<b>.07</b> √F(GHz) dB Maxi
RF leakage	- (	<b>65</b> - F(GHz)) dB Maxi
Voltage rating		<b>170</b> Veff Maxi
Dielectric withstanding voltage		<b>500</b> Veff mini
Insulation resistance		<b>5000</b> MΩ mini

**CABLE ASSEMBLY**

Stripping	a	b	c	d	e	f
mm	2.00	6.00	8.00	0.00	0.00	0.00

Assembly instruction : **Crimp 05**

Recommended cable(s)  
RD 316  
K02252D

Cable retention  
- pull off **110** N mini  
- torque **NA** N.cm

**MECHANICAL CHARACTERISTICS**

Center contact retention		
Axial force – Mating end	<b>10</b>	N mini
Axial force – Opposite end	<b>10</b>	N mini
Torque	<b>NA</b>	N.cm mini

**TOOLING**

Part Number	Description	Hexagon
.	.	.
R282.271.000	CRIMPING TOOL	3.84
R282.235.037	CRIMPING DIES	3.84
R282.293.000	CRIMPING TOOL	

Recommended torque		
Mating	<b>NA</b>	N.cm
Panel nut	<b>NA</b>	N.cm
Clamp nut	<b>NA</b>	N.cm
A/F clamp nut	<b>0.000</b>	mm

Mating life	<b>1000</b>	Cycles mini
Weight	<b>1.300</b>	g

**OTHERS CHARACTERISTICS**

**ENVIRONMENTAL**

Operating temperature	<b>-65/+165</b>	° C
Hermetic seal	<b>NA</b>	Atm.cm3/s
Panel leakage	<b>NA</b>	

Issue : **0227 B**

In the effort to improve our products, we reserve the right to make changes judged to be necessary.

